

Atlas Copco

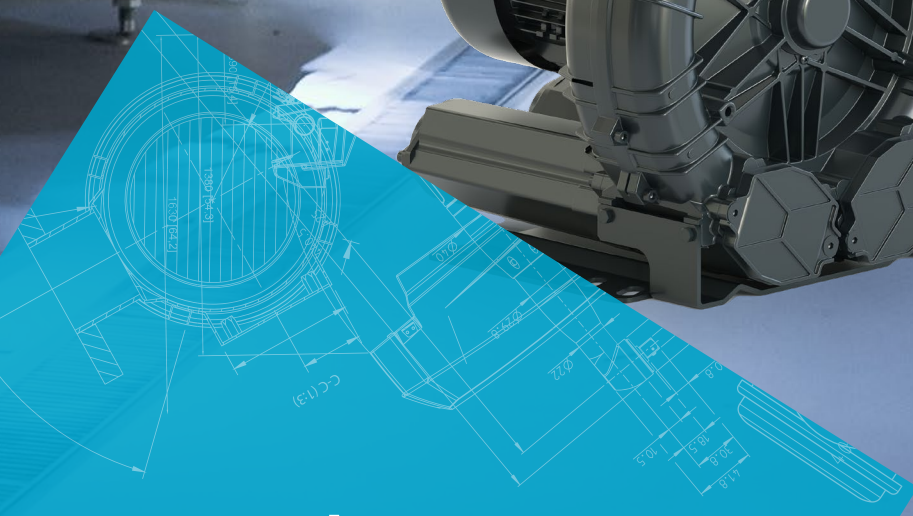

## DB Series

Side Channel Blowers





At Atlas Copco, our industrial ideas empower our customers to grow and drive society forward. This is how we create a better tomorrow. Built on a strong legacy of innovation and reliability, we always aim to offer our customers with solutions that most suit their needs. Our vacuum engineers and designers are always on a journey of innovation to add new products to our already comprehensive portfolio of vacuum pumps and systems.

## DB Series Side Channel Blowers

Introducing the Atlas Copco DB series Side Channel Blowers - a tested and reliable technology for rough vacuum level and low pressure as well, suitable for industrial application in the most efficient way possible.

Available in single and double-stage variants the DB series do not require oil to operate. This ensures a clean operation, free of emissions and no contamination to the process. They are designed to be robust, clean, compact, and silent suited for rough industrial applications with high efficiency. The modular construction of DB side channel blowers ensures efficient performance with minimal energy consumption.

### DBS - Single stage and single impeller

Ideal for applications requiring flow rates up to 1000 m<sup>3</sup>/h for regular vacuum levels up to -350 mbar.

### DBD - Double stage and single impeller

Ideal for applications that need limited flow demand with vacuum levels up to -450 mbar.



### DBSt - Twin impellers and single stage

The twin impellers working in parallel allow for large quantities of suction air up to 1980 m<sup>3</sup>/h with discrete vacuum levels up to -300 mbar.

The twin impeller variant increases the flow capacity of the blower.



### DBDt - Twin impellers and double stage

Double stage and twin impellers allow to manage high flow rates and higher vacuum levels. They are the most complex models to match demanding applications.

The double stage variant increases both the pressure difference and the flow rate of the blower.



## Working principle

Side channel blowers operate by transferring kinetic energy through a rotating impeller. The impeller, available in single or twin variants, are direct fixed to the motor shaft enabling (direct driven transmission) suction for the pumped medium. This is subsequently compressed in the side channel. Available in single and double-stage variants, the DB series can be used to generate both vacuum and compressed air with capacities and differential pressure as needed for your process.

DBS

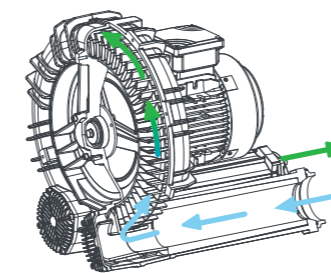

DBD

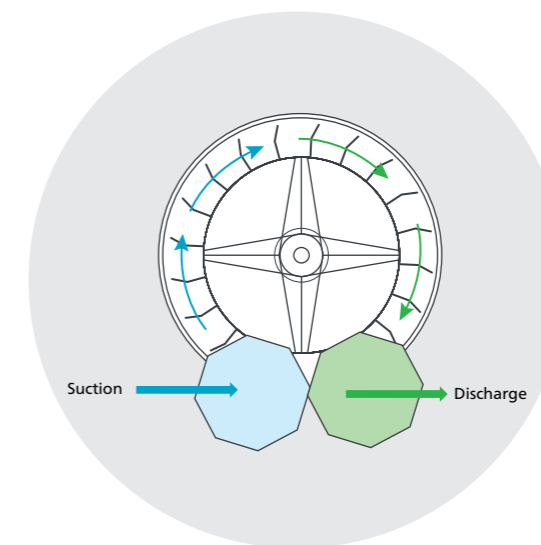
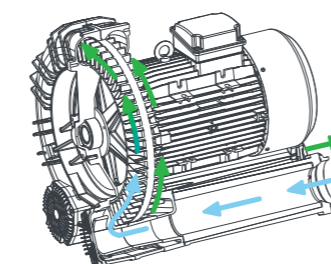

DBSt

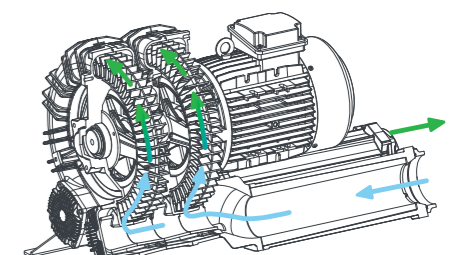

DBDt

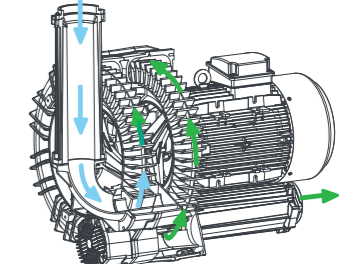

## Features & benefits



### Efficiency

The DB series are highly efficient blowers with low energy consumption across the range. Equipped as standard on all models are IE3 motors according to Ecodesign 2009//125/CE, complying cURus standards for US and Canadian markets.



### Dry, clean and oil free

Due to the non-contact and oil free working principle, the DB series have clean exhaust air without oil and dust contamination.



### Robust and reliable

Housed in a fully enclosed aluminium unit with optional PTO thermal protection and long-life bearings, the DB series side channel blowers are robust and reliable.



### Minimal maintenance

Due to its modular design, non-contacting parts, and the absence of oil or exhaust filters the DB series is nearly maintenance free.



### Adaptive for global installations

The DBS series are available in a wide range of voltages and both 50 and 60 Hz frequencies.



### Low noise levels

Due to the effective blade design and integrated silencers both in suction and discharge, our blowers have slow sound impact, making the work environment more pleasant.

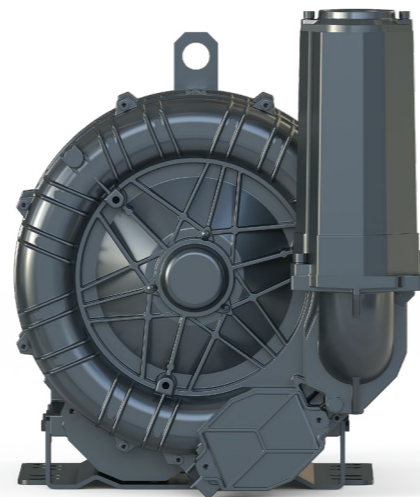

## Technical specifications

	Unit	DBS (Mono/Single)	DBSt (Mono/Double)	DBD (Twin/Single)	DBDt (Twin/Double)	
Max. capacity	m <sup>3</sup> /h (cfm)	50Hz	74 – 1022 (43.5-601.5)	408 – 1985 (240-1168)	91 – 430 (53.6-253)	139 – 1007 (81.8-593)
		60Hz	89 – 1234 (52.4-726.3)	493 – 2382 (290-1402)	110 – 519 (64.7-305.5)	168 – 1216 (99-715.73)
Max. pressure	mbar (torr)	50Hz	+100 – +400 (75-300)	+130 – +375 (97.5-281)	+325 – +550 (247.7-412.5)	+275 – +550 (206.2-412.5)
		60Hz	+75 – +375 (56-281)	+105 – +325 (78.7-247.7)	+300 – +550 (225-412.5)	+225 – +525 (168.7-393.7)
Max. vacuum	mbar (torr)	50Hz	-100 – -350 (675-488)	-130 – -300 (652-525)	-300 – -450 (525-412)	-275 – -450 (544-420)
		60Hz	-75 – -325 (694-506)	-105 – -300 (671-525)	-320 – -450 (525-412)	-225 – -475 (581-394)
Motor power	kW (hp)	50Hz	0.37 – 15 (0.5-20)	3.0 – 22.0 (4-29.5)	1.1 – 7.5 (1.5-10)	2.2 – 22.0 (3-29.5)
		60Hz	0.4 – 22 (0.5-29.5)	3.5 – 26 (4.7-35)	1.3 – 11 (1.7-14.7)	2.6 – 26 (3.5-35)
Number of models	50Hz	32	22	9	17	
	60Hz	35	22	10	19	

## Accessories

DBS	70	140	220/300	410/480/540	660/780/910/1020	-
DBSt	-	-	-	410/560	830/1010	1320/1540/1760/1980
DBS Inlet/Outlet connection (G/DN)	1 1/4" / 32	1 1/2" / 40	2" / 50	3" / 80	4" / 100	-
DBSt Inlet/Outlet connection (G/DN)	-	-	-	3" / 80	4" / 100	5" / 125
Manifold	✓	✓	✓	✓	✓	✓
IF (Compressor mode)	✓	✓	✓	✓	✓	✓
Inlet vacuum cyclone filter	✗	✓	✓	✓	✓	✗
Cyclone double filter	✗	✓	✓	✓	✓	✗
Inlet protect filter (Compressor mode)	✓	✓	✓	✓	✓	✓
Vacuum filter (Paper/polyester)	✓/✗	✓/✓	✓/✓	✓/✓	✓/✓	✓/✗
Clogging indicator (Optical or electric)	✗	✓	✓	✓	✓	✓
Inlet protection	✓	✓	✓	✓	✓	✓
Pressure gauge 0-600 mbar / 0-1000 mbar	✓	✓	✓	✓	✓	✓
Vacuum gauge -1-0 bar(e) / 0-1000 mbar(a)	✓	✓	✓	✓	✓	✓
Nipple NP	✓	✓	✓	✓	✓	✗
Valve holder VH	✓	✓	✓	✓	✓	✓
Inline silencer	✓	✓	✓	✓	✓	✗
Final silencer	✓	✓	✓	✓	✓	✗
Connection S	✓	✓	✓	✓	✓	✓
Non-return valve	✓	✓	✓	✓	✓	✓
Relief valve	✓	✓	✓	✓	✓	✓
Manifold for vertical inst. VIM	✗	✓	✓	✓	✓	✓

DBD	90	-	180/240	-	-	310/390/430	-
DBDt	-	140	-	210/310	420/520	-	660/800/900/1010
DBD Inlet/Outlet connection (G/DN)	1 1/4" / 32	-	2" / 50	-	-	4" / 100	-
DBDt Inlet/Outlet connection (G/DN)	-	1 1/2" / 40	-	2" / 50	3" / 80	-	4" / 100
Manifold	✓	✗	✓	✗	✗	✓	✗
IF (Compressor mode)	✓	✓	✓	✓	✓	✓	✓
Inlet vacuum cyclone filter	✗	✓	✓	✓	✓	✓	✓
Cyclone double filter	✗	✓	✓	✓	✓	✓	✓
Inlet protect. filter (Compressor mode)	✓	✓	✓	✓	✓	✓	✓
Vacuum filter (Paper/polyester)	✓/✗	✓	✓/✓	✓	✓	✓/✓	✓
Clogging indicator (Optical or electric)	✗	✓	✓	✓	✓	✓	✓
Inlet protection	✓	✓	✓	✓	✓	✓	✓
Pressure gauge 0-600 mbar / 0-1000 mbar	✓	✓	✓	✓	✓	✓	✓
Vacuum gauge -1-0 bar(e) / 0-1000 mbar(a)	✓	✓	✓	✓	✓	✓	✓
Nipple NP	✓	✓	✓	✓	✓	✓	✓
Valve holder VH	✓	✓	✓	✓	✓	✓	✓
Inline silencer	✓	✓	✓	✓	✓	✓	✓
Final silencer	✓	✓	✓	✓	✓	✓	✓
Connection S	✓	✓	✓	✓	✓	✓	✓
Non-return valve	✓	✓	✓	✓	✓	✓	✓
Relief valve	✓	✓	✓	✓	✓	✓	✓
Manifold for vertical inst. VIM	✗	✗	✗	✗	✗	✗	✗



# Applications

- Roller cleaning
- Pneumatic conveying
- Adhesive films
- Furniture sublimation printing systems
- Pick & place
- Yarn processing
- Vacuum tables
- Drying (Stickers, surfaces, polymers)
- Wine production
- Pad printing
- Wastewater treatment
- Paper cutting
- Auto body shops
- Suction (Condensation, excess paint, shavings, dust)



# Performance curves

Vacuum: DBS and DBSt @ 50Hz

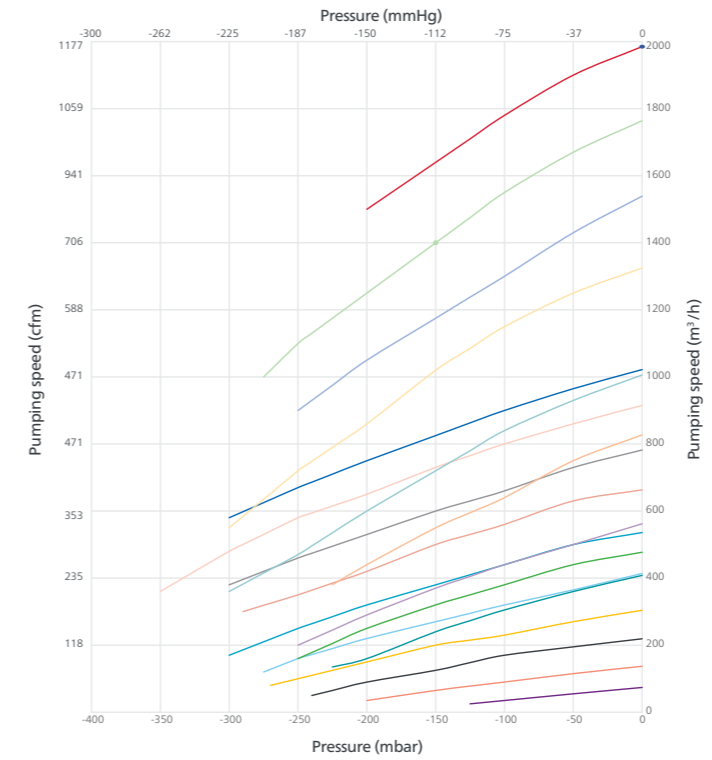

- DBS 70-150
- DBS 140-200
- DBS 220-250
- DBS 300-340
- DBS 410-275
- DBS 480-250
- DBS 540-350
- DBS 660-290
- DBS 780-300
- DBS 910-400
- DBS 1020-300
- DBS 1020-375
- DBS 1320-350
- DBSt 560-300
- DBSt 830-225
- DBSt 1760-275
- DBSt 1980-200
- DBSt 1540-250

Vacuum: DBD and DBDt @ 50Hz

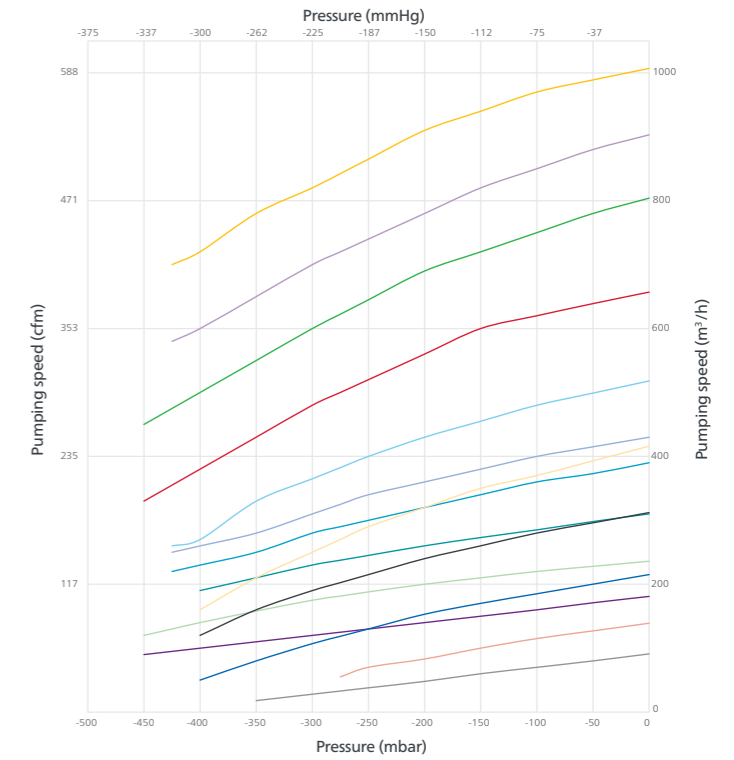

- DBD 90-425
- DBD 180-550
- DBD 240-550
- DBD 310-425
- DBD 390-515
- DBDt 140-400
- DBDt 210-475
- DBDt 240-550
- DBDt 310-425
- DBDt 420-475
- DBDt 420-475
- DBDt 1010-425
- DBDt 800-450
- DBDt 900-475

Vacuum: DBS and DBSt @ 60Hz

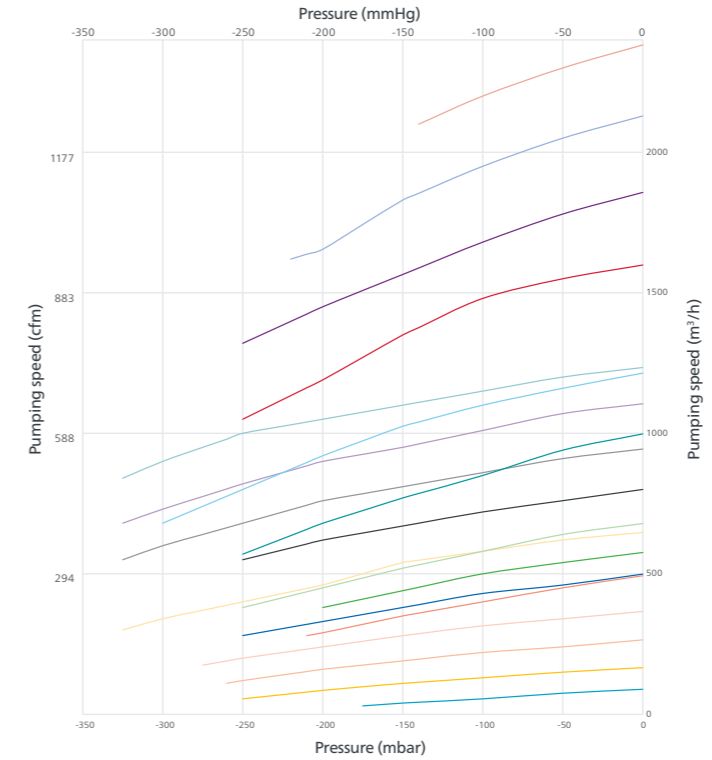

- DBS 70-150
- DBS 140-250
- DBS 220-250
- DBS 300-340
- DBS 410-275
- DBS 480-250
- DBS 540-350
- DBS 660-290
- DBS 780-325
- DBS 910-400
- DBS 1020-375
- DBS 1020-375
- DBS 1320-350
- DBSt 560-300
- DBSt 830-250
- DBSt 1760-275
- DBSt 1980-200
- DBSt 1540-250

Vacuum: DBD and DBDt @ 60Hz

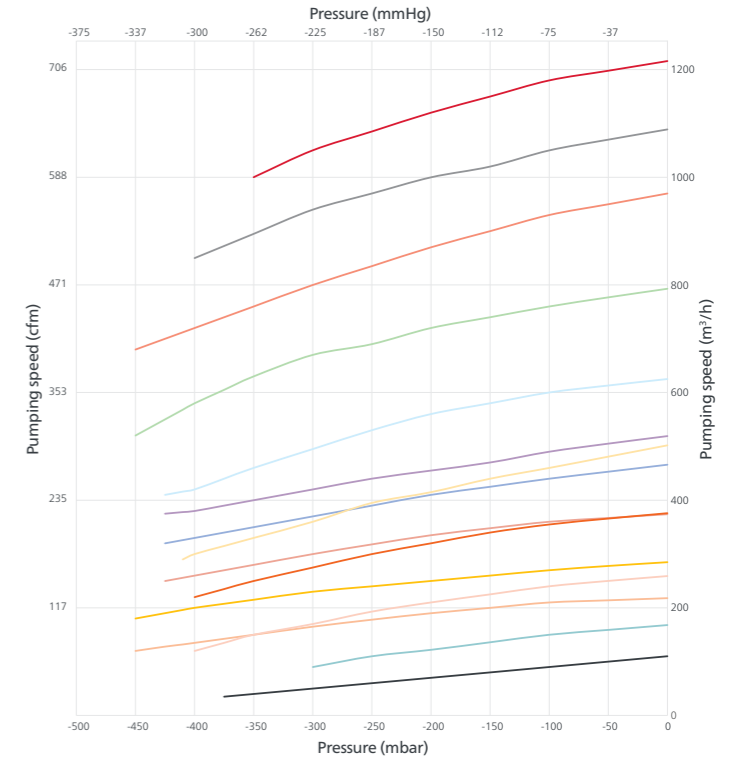

- DBD 90-425
- DBD 180-550
- DBD 240-550
- DBD 310-425
- DBD 390-515
- DBDt 140-400
- DBDt 210-475
- DBDt 240-550
- DBDt 310-425
- DBDt 420-475
- DBDt 420-475
- DBDt 1010-425
- DBDt 800-525
- DBDt 900-475





## DBSt

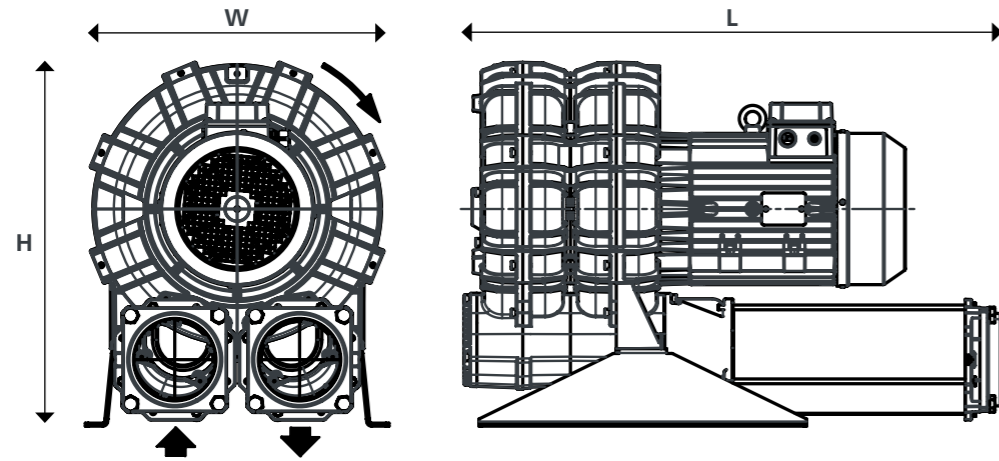

Model	Length		Width		Height		Weight		Inlet/Outlet connection
	mm	in	mm	in	mm	in	kg	lbs	
DBSt 410-175	678	26.6	404	15.9	422	16.6	48	105.8	G 3"
DBSt 410-250	678	26.6	404	15.9	422	16.6	49.5	109.1	G 3"
DBSt 560-130	706	27.7	404	15.9	455	17.9	55.5	122.3	G 3"
DBSt 560-200	706	27.7	404	15.9	455	17.9	71.5	157.6	G 3"
DBSt 560-300	706	27.7	404	15.9	455	17.9	76.5	168.6	G 3"
DBSt 830-150	843	33.1	470	18.5	531	20.9	93.5	206.1	G 4"
DBSt 830-225	843	33.1	470	18.5	531	20.9	98.5	217.1	G 4"
DBSt 830-250	843	33.1	470	18.5	531	20.9	110	242.5	G 4"
DBSt 1010-140	843	33.1	480	18.8	548	21.5	104	229.2	G 4"
DBSt 1010-210	843	33.1	480	18.8	548	21.5	109	240.3	G 4"
DBSt 1010-260	843	33.1	480	18.8	548	21.5	115.5	254.6	G 4"
DBSt 1010-375	843	33.1	480	18.8	548	21.5	133	293.2	G 4"

Model	Length		Width		Height		Weight		Inlet/Outlet connection
	mm	in	mm	in	mm	in	kg	lbs	
DBSt 1320-190	901	35.4	510	20	610	24	136.5	300.9	G 5"
DBSt 1320-250	901	35.4	510	20	610	24	157	346.1	G 5"
DBSt 1320-350	901	35.4	510	20	610	24	183.5	404.5	G 5"
DBSt 1540-160	901	35.4	516	20.3	623	24.5	139.5	307.5	G 5"
DBSt 1540-200	901	35.4	516	20.3	623	24.5	160	352.71	G 5"
DBSt 1540-250	901	35.4	516	20.3	623	24.5	186.5	411.1	G 5"
DBSt 1760-160	921	36.2	542	21.3	650	25.5	173.5	382.5	G 5"
DBSt 1760-220	921	36.2	542	21.3	650	25.5	200	440.9	G 5"
DBSt 1760-275	921	36.2	542	21.3	650	25.5	209.5	461.8	G 5"
DBSt 1980-150	931	36.6	548	21.5	653	25.7	200	440.9	G 5"
DBSt 1980-200	931	36.6	548	21.5	654	25.7	209.5	461.8	G 5"

## DBDt

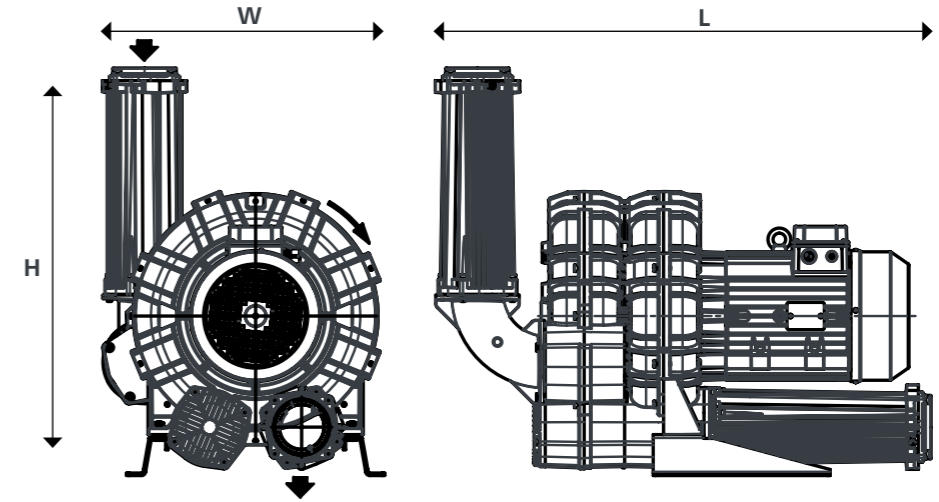

Model	Length		Width		Height		Weight		Inlet/Outlet connection
	mm	in	mm	in	mm	in	kg	lbs	
DBDt 140-400	458	18	285	11.22	327	12.8	30.5	67.2	G 1" 1/2
DBDt 210-350	494	19.4	327	12.8	443	17.4	44.5	98.1	G 2"
DBDt 210-475	514	20.2	327	12.8	443	17.4	45.5	100.3	G 2"
DBDt 310-275	519	20.4	376	14.8	473	17.4	52.5	115.7	G 2"
DBDt 310-425	604	23.7	376	14.8	473	17.4	68.5	151	G 2"
DBDt 310-525	604	23.7	376	14.8	473	17.4	73.5	162	G 2"
DBDt 420-350	691	27.2	470	18.5	698	27.4	89.5	197.3	G 3"
DBDt 420-475	691	27.2	470	18.5	698	27.4	94.5	208.3	G 3"
DBDt 520-375	691	27.2	480	18.8	698	27.4	100.5	221.5	G 3"
DBDt 520-425	691	27.2	480	18.8	698	27.4	105.5	232.5	G 3"

Model	Length		Width		Height		Weight		Inlet/Outlet connection
	mm	in	mm	in	mm	in	kg	lbs	
DBDt 660-390	979	38.5	548	21.5	806	31.7	103.5	228.1	G 4"
DBDt 660-550	979	38.5	548	21.5	806	31.7	151	332.8	G 4"
DBDt 800-325	979	38.5	560	22	806	31.7	137	302	G 4"
DBDt 800-450	979	38.5	560	22	806	31.7	154	339.5	G 4"
DBDt 800-525	979	38.5	560	22	806	31.7	180.5	397.9	G 4"
DBDt 900-375	999	39.3	595	23.4	831	32.7	167.5	369.2	G 4"
DBDt 900-475	999	39.3	595	23.4	831	32.7	194	427.6	G 4"
DBDt 1010-300	1012	39.8	598	23.5	813	32	201	443.1	G 4"
DBDt 1010-425	1012	39.8	598	23.5	813	32	203.5	448.6	G 4"

## DBD

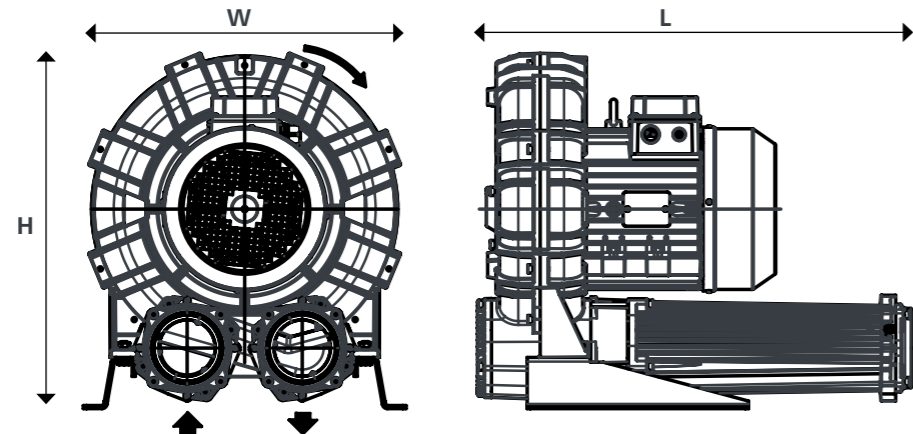

Model	Length		Width		Height		Weight		Inlet/Outlet connection
	mm	in	mm	in	mm	in	kg	lbs	
DBD 90-325	390	15.3	319	12.5	346	13.6	25	55.1	G 1" 1/4
DBD 90-425	390	15.3	319	12.5	346	13.6	25	55.1	G 1" 1/4
DBD 180-450	452	17.7	470	18.5	481	18.9	51.8	114.1	G 2"
DBD 180-550	452	17.7	470	18.5	481	18.9	53	116.8	G 2"
DBD 240-400	452	17.7	480	18.8	498	19.6	56.5	124.5	G 2"

Model	Length		Width		Height		Weight		Inlet/Outlet connection
	mm	in	mm	in	mm	in	kg	lbs	
DBD 240-550	452	17.7	480	18.8	498	19.6	70	154.3	G 2"
DBD 310-425	685	26.9	510	20	561	22	84	185.1	G 4"
DBD 390-515	685	26.9	516	20.3	573	22.5	91	200.6	G 4"
DBD 430-425	695	27.3	542	21.3	603	23.7	98.5	217.1	G 4"
DBD 430-420	695	27.3	542	21.3	603	23.7	110	242.5	G 4"

## Service support and maintenance



### Complete service with our Preventive Care plan

We take over the maintenance planning and responsibility for servicing your vacuum pump on a regular basis. Our Preventive Care plan is tailored to your pump's needs. As your pump is serviced with the latest technology, high levels of energy efficiency are achieved. We will also optimize service events to reduce your total cost of ownership and increase your productivity. This allows you to focus fully on your production.



### Maximize lifetime of your vacuum pumps

Our vacuum specialists are well-trained and experts in the field. They will help you to improve uptime and protect your processes. Regular maintenance conducted by one of our vacuum specialists reduces the risk of deterioration. Damaged or worn parts will be replaced with genuine Atlas Copco spare parts to protect your investment and increase the lifespan of your vacuum pumps.



### Cost-effective approach

Regular scheduled maintenance can identify potential problems before they occur and plans can be structured around your individual production situation. Preventive Care enables cost management as you can plan your maintenance costs in advance. In this way, expenses associated with unplanned downtime are minimized.



### Reliability meets non-stop productivity

We use genuine Atlas Copco spare parts and oil and our services are conducted by vacuum specialists. This enhances your vacuum pump performance, reducing the risk of downtime and enabling your production to run more smoothly.



Atlas Copco AB  
[atlas-copco.com/vacuum](https://atlas-copco.com/vacuum)

