



# 2 STAGE OIL-SEALED ROTARY VANE VACUUM PUMPS

Atlas Copco

GVD 175-275



## FEATURES AND BENEFITS

- Advanced pressurized oil circuit to give effective lubrication even under high gas loads.
- When the pump is switched off, the spring loaded distributor valve provides oil and air suck-back protection.
- Gas ballast control to assist in handling high water vapor loads.
- Industrial roller bearings on drive shaft for ultimate reliability and long, trouble free life.
- Full height oil sight glass for easy checking of oil level and condition.
- Easy change oil filter, with oil filter condition gauge on larger models.
- Central inlet port to allow easy mounting of mechanical booster pump if required.
- Easy to maintain, with convenient service kits and international customer support.
- A wide range of accessories to match your application needs
- The pumps and accessories can be supplied either as individual components or as fully systemized, factory-tested combinations.

## TECHNICAL SPECIFICATIONS GVD 175-275

	GVD 175		GVD 275	
	50 Hz	60 Hz	50 Hz	60 Hz
Displacement	178 m <sup>3</sup> h <sup>-1</sup> / 105 cfm	214 m <sup>3</sup> h <sup>-1</sup> / 126 cfm	292 m <sup>3</sup> h <sup>-1</sup> / 172 cfm	350 m <sup>3</sup> h <sup>-1</sup> / 206 cfm
Speed (Pneurop 6602)	160 m <sup>3</sup> h <sup>-1</sup> / 94 cfm	196 m <sup>3</sup> h <sup>-1</sup> / 115 cfm	255 m <sup>3</sup> h <sup>-1</sup> / 150 cfm	306 m <sup>3</sup> h <sup>-1</sup> / 180 cfm
Ultimate vacuum (total pressure) without gas ballast	1 x 10 <sup>-3</sup> mbar / 7.7 x 10 <sup>-4</sup> Torr		1 x 10 <sup>-3</sup> mbar / 7.7 x 10 <sup>-4</sup> Torr	
Ultimate vacuum (total pressure) with gas ballast	5 x 10 <sup>-3</sup> mbar / 3.8 x 10 <sup>-3</sup> Torr		5 x 10 <sup>-3</sup> mbar / 3.8 x 10 <sup>-3</sup> Torr	
Inlet connection suitable for	DN63 ISO-KF		DN63 ISO-KF	
Outlet connection suitable for	DN40 ISO-KF		DN40 ISO-KF	
Max. outlet pressure	0.5 bar / 7 psig gauge		0.5 bar / 7 psig gauge	
Max. inlet pressure for water vapor	20 mbar / 15 Torr		12 mbar / 9 Torr	
Max. water vapor pumping rate	0.3 kg h <sup>-1</sup> / 0.7 lb h <sup>-1</sup>		2.3 kg h <sup>-1</sup> / 5.1 lb h <sup>-1</sup>	
Weight (without oil)	230 kg / 508 lb		253 kg / 558 lb	
Motor protection rating	IP55		IP55	
Motor power	5.5 kW / 7.5 hp	6.5 kW / 8.5 hp	7.5 kW / 10 hp*	8.5 kW / 11 hp*
Maximum oil capacity	25 litre / 26 qt		28 litre / 29.5 qt	
Minimum oil capacity	16 litre / 17 qt		19 litre / 20 qt	
Noise level	75 dB (A)		75 dB (A)	
Water cooling requirement	1.3 lmin <sup>-1</sup> @ maximum 30°C		1.3 lmin <sup>-1</sup> @ maximum 30°C	

\* GVD 275 7.5 kW/9.2 kW at 50/60 Hz.  
All motors are 3-phase energy-efficient.  
IEC EN60034.



# APPLICATIONS

- Refrigeration and air conditioning system evacuation, drying, and backfilling
- Vacuum drying and distillation
- Backing pump for high vacuum applications
- Vacuum metallurgy processes
- Thin film coating technologies
- Freeze drying
- Transformer and cable drying and impregnation, insulating oil treatment plant
- Cryogenic vessel evacuation

# DIMENSIONS

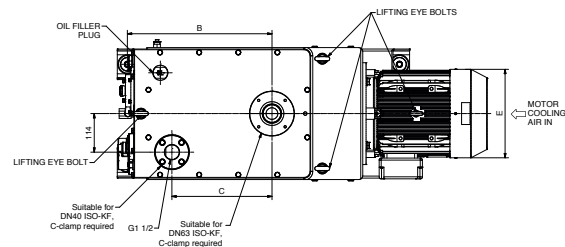
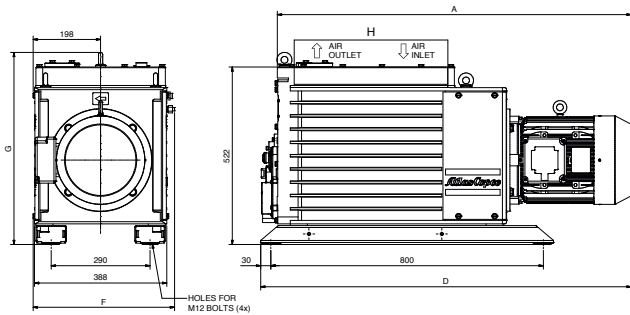

MODEL	A	B	C	D	E	F	G
GVD 175	941	329	196	994	256	410	563
GVD 275	1130	425	294	1185	260	415	565

# PERFORMANCE CURVES

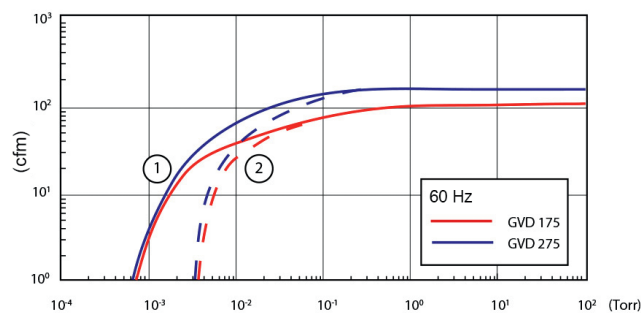
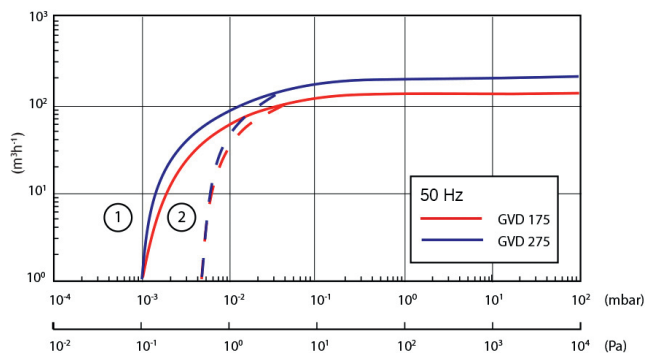

1: Without gas ballast.  
2: With gas ballast open.

Available motor voltages:  
• 400 V 50 Hz  
• 460 V 60 Hz NEMA premium  
• 200/380 Hz 50/60 Hz

For ultimate vacuum figures, please consult the technical specification table on the front page.



www.atlascopco.com/vacuum